

Velontra Overview

Vision

Jet Engines are a Prime Mover of Society

but...

No meaningful innovation in 75 years



Vision

**Velontra will
revolutionize
the jet engine**

Vision

Revolution enabled by New Space methods

- Pioneered in the 1960's
- Revitalized by SpaceX in the 2000's

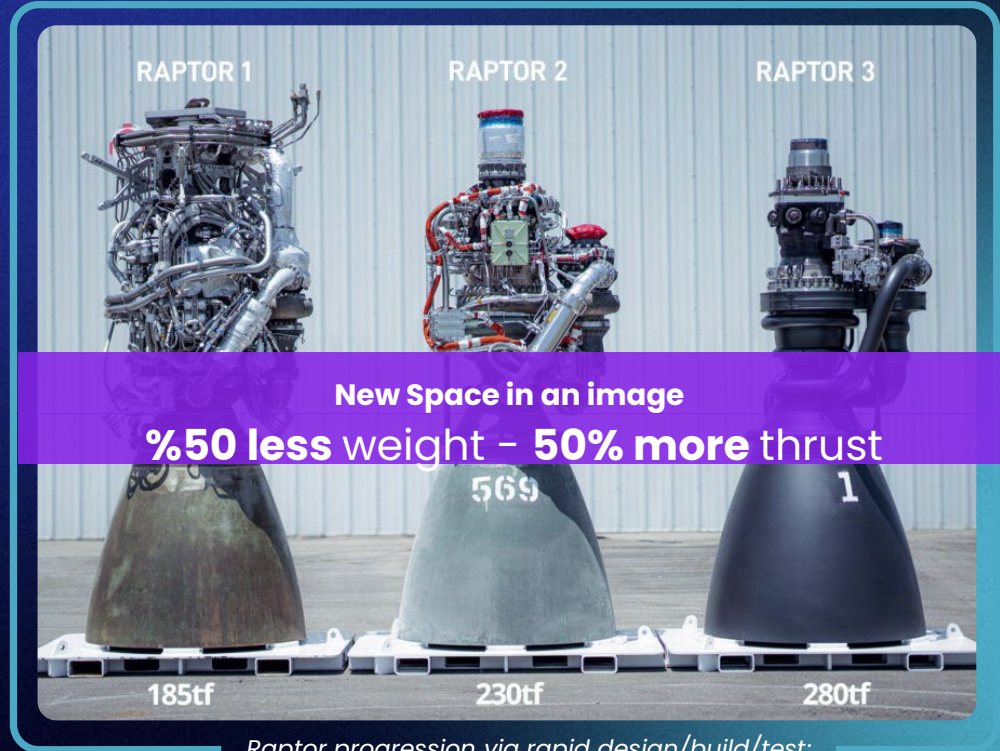

Raptor progression via rapid design/build/test;
(Credit SpaceX, TeslaOracle)

RAPTOR 1

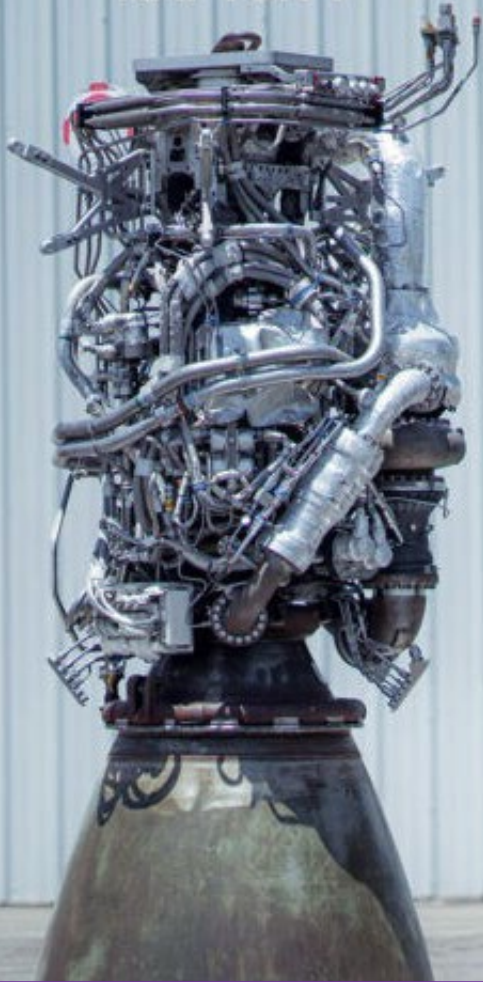

185tf

RAPTOR 2



569

230tf

RAPTOR 3



1

280tf

Pitch Deck

March 2026

Velontra will do this for jet engines!

Vision

With its Development Methods and Engine Technology, Velontra will ...

Power the thousands of jet powered drones our country needs

Enable new drone and aircraft designs not possible today like runway orbit access

Create derivative products like power generation turbines for data centers

Eventually unseat engine OEM like GE and PW – innovators dilemma style

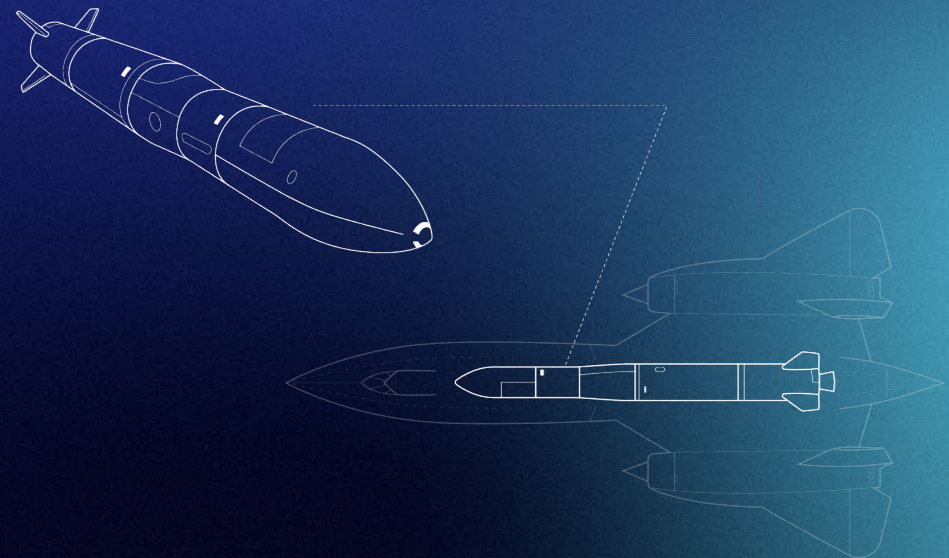

TEAM



Joel Darin
CEO/CTO/Founder

- + Hermeus Employee #1
- + Next-gen fighter jet engines at GE Aviation
- + PhC from Georgia Tech



Eric Briggs
COO

- + Head of engines at Virgin Orbit
- + 20 years experience

+ Team of 11

- ✓ New Space
- ✓ Old Space
- ✓ Defense + OEM
- ✓ Academia + Research

Advisory Board



Dan Summers
Board of Advisors
Former GE Aviation, SpaceX
Led Raptor Production Team



Chris Beck
Board of Advisors
Metal 3D Printing Expert
CEO Innovative 3D Manufacturing



Art Suckewer
Board of Advisors
Ignition System Expert
CEO Knite Inc



Nancy Currie-Gregg
Board of Advisors
4x Shuttle Astronaut
NASA Chief Engineer



Jonathan George
Board of Advisors
Brig Gen (ret)
Pres Obamas Nat Security Council



Craig Whelden
Board of Advisors
Maj Gen (ret), former SES USMC
Strategic Expertise

Real Revenue – Real Traction

- **YC S22, \$2.5M** pre-seed, **\$9.5M** revenue*
- **8 DoD** contracts, **3 commercial** contracts
- **\$1.8M** contract with USAF to retrofit surplus engines with Pre-Seed Ramburner technology
- **\$2.5M** Congressional Interest Item (CII) for the development of Hypersonic Engines
- **9 LOI/Memo/LOS** from influential DoD / Private Industry entities including **Anduril**

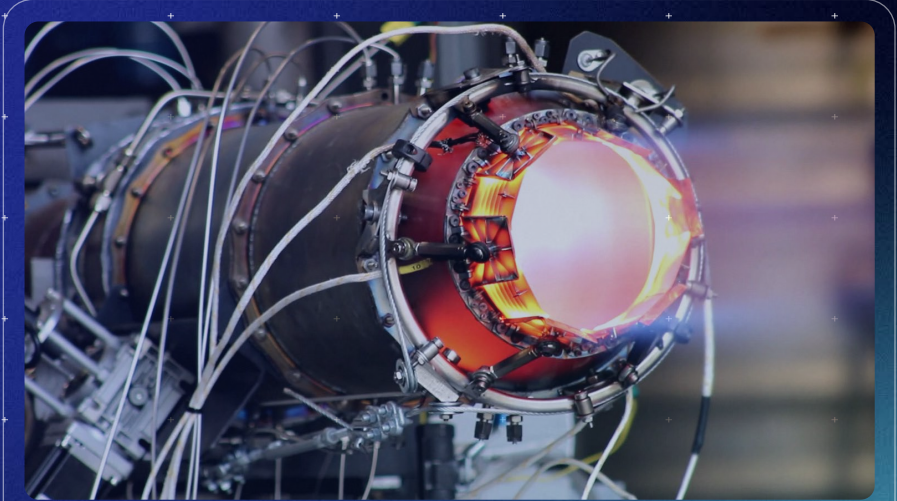

*includes FY26 CII



Building a Small Turbojet Engine

Pre-Seed
Demo (TRL3)



Design completed 9 weeks from clean sheet

10-20k engines per year
@ 25-35k unit cost

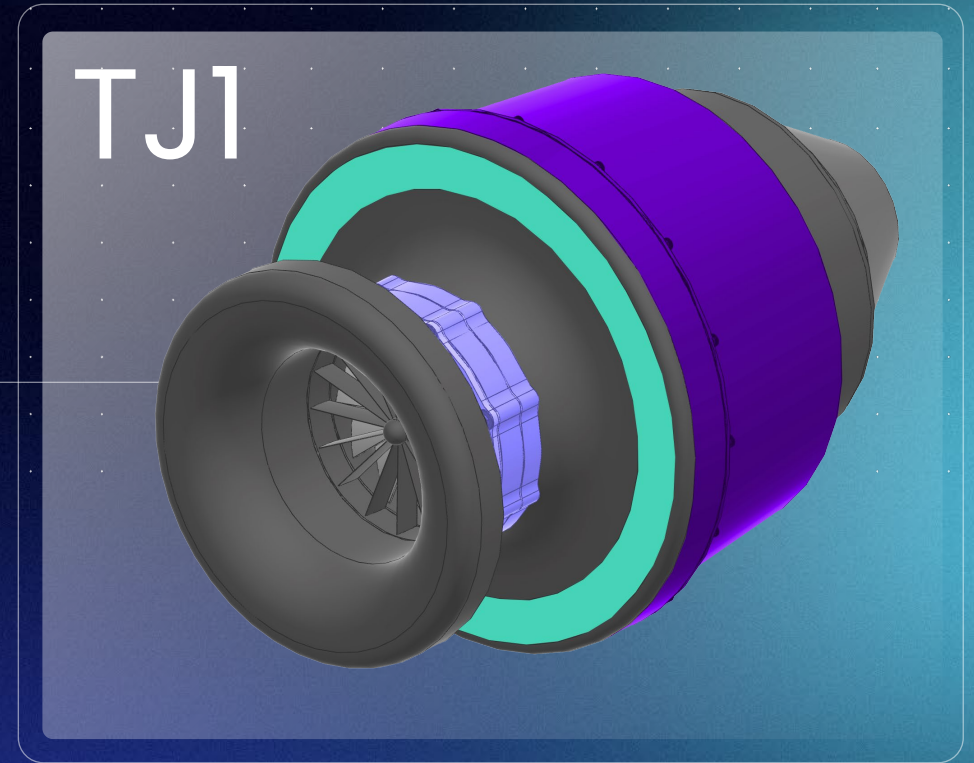

Seed
Prototype (TRL8)

TJ1 at TRL8 **unlocks** Program of Record

Why Now?

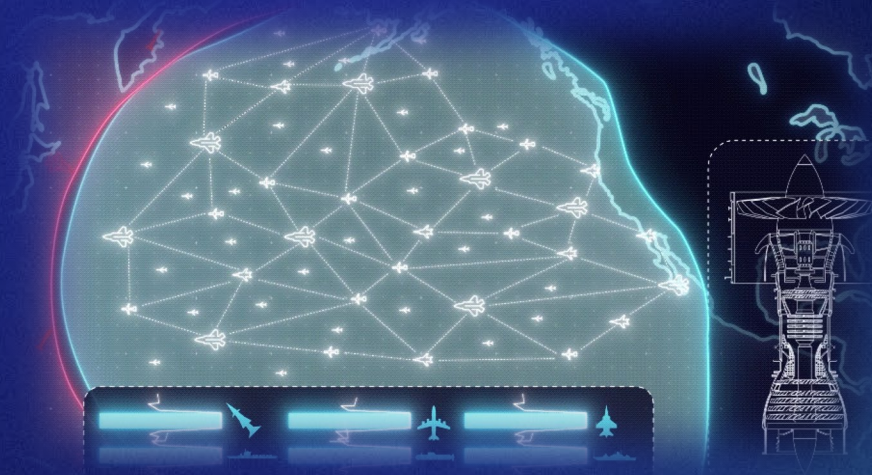

1. New era of warfare
2. Resurgence of Defense Tech



Today



**New era of warfare is
unmanned,
autonomous and
low cost**

Today

**Current
drones use
business jet
engines**

NOT low cost



Today

Plethora of other
drones with no
engine options ...

Enter Velontra



\$10M Seed Round



Thanks!



Backup



We apply “New Space” to Jet Engines

**Drastically
cheaper engines,
developed much
faster**

	Velontra	Primes
Rapid design-build-test cycles	✓	✗
Vertically integrated manufacturing	✓	✗
Cost and scale as design objectives	✓	✗
Minimal overheads	✓	✗
Cost (\$/lbf)	<\$100	\$900-\$1500



We apply "New Space" to Jet Engines

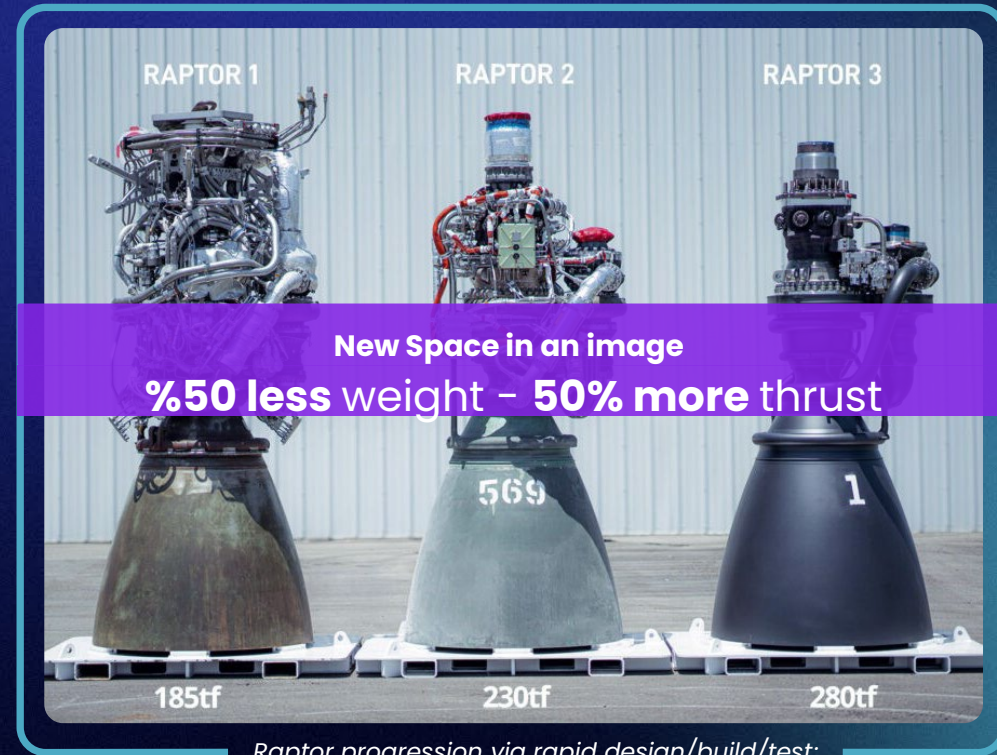

Raptor progression via rapid design/build/test;
(Credit SpaceX, TeslaOracle)

Ramburner Technology

- Velontra developed its Bronco ramburner during its seed round
- Ramburner = combustor able to directly ingest and burn ram air from upstream and expand out a nozzle
- Ramburner is called an afterburner when coupled to a gas turbine
- Bronco was used in an afterburning turbojet (pictured)
- Bronco was used in a rocket based combined cycle (RBCC)



Afterburning Jet Engines

- Velontra has afterburner (ramburner) technology developed with seed funding
- Eventually CCA engines will need afterburners (have signed memo from customer)
- No current options for afterburning UAV propulsion (including CCA)
- Velontra will offer afterburning versions of every engine – **competitors can't match this performance**

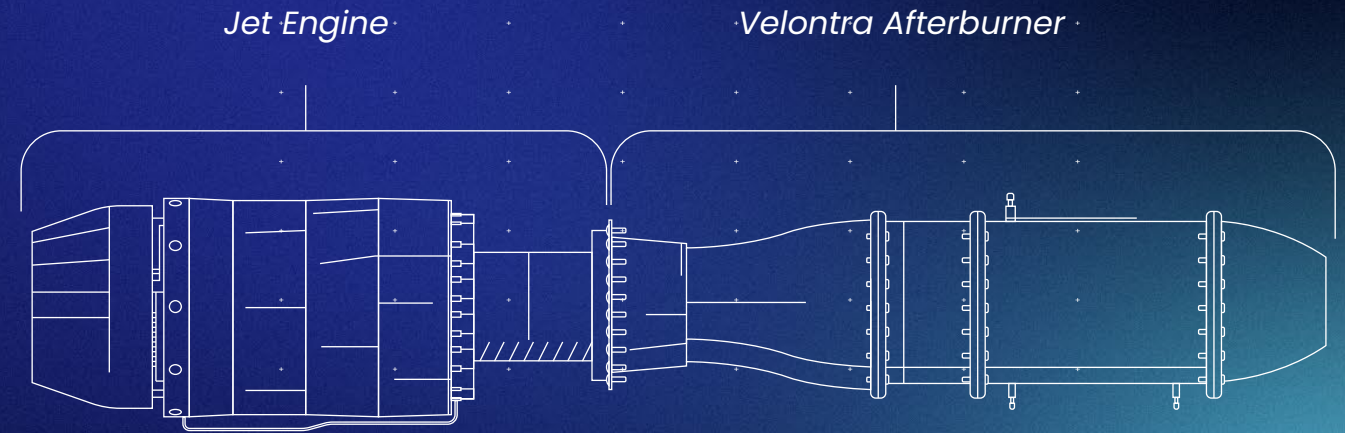

Afterburners instantaneously double the thrust of an engine without increasing its cross-sectional area

Hypersonic Engine

- Velontra tech development **culminates** in a hypersonic engine (TBCC)
- **Hypersonic CCAs** will exist in the future (have signed memo and customer testimony)
- **No TBCC option** exists today – Velontra TBCC (called TBI) will be only option
- Long term – TBI enables **orbit access** from runways

Turbine Based Combined Cycle (TBCC)

Jet Engine + Ramburner = TBCC

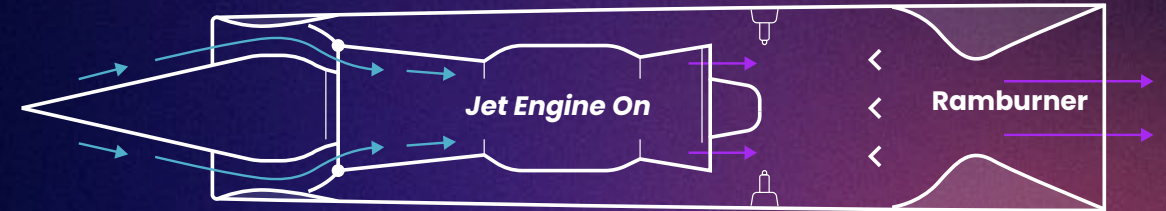

1. **Jet Engine Mode (Mach 0-3)**: Normal jet engine

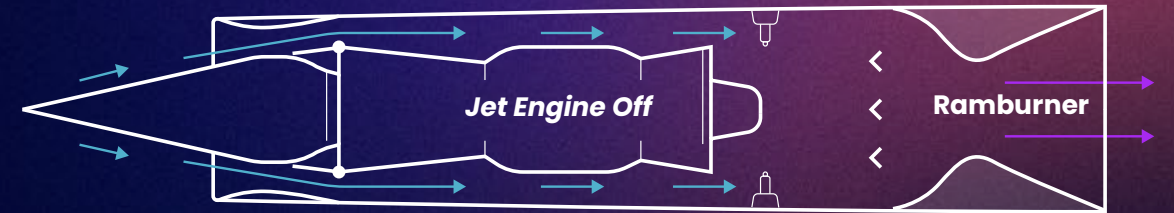

2. **Ramjet Mode (Mach 3-5)**: Jet engine off, flow diverted around jet engine into ramburner

HyperLaunch

- Velontra TBCC enables **HyperLaunch** – orbit access from conventional runways
- **HyperLaunch**
 - is a **hypersonic** 1st stage **aircraft** and rocket 2nd stage
 - **commoditizes** orbit access
 - **enables** *Tactically Responsive Space Access (TacRS)* for DoD
 - provides orbit access for countries **with no native launch capability**
- **HyperLaunch** would enable payloads to orbit like FedEx ships air freight today

